

La Welding Technology è un'azienda che produce principalmente macchinari ed accessori per procedimenti di saldatura in arco sommerso e vanta l'esperienza trentennale del titolare in tale settore.

Ogni prodotto è pensato, studiato e progettato al suo interno.

L'azienda dispone di una sua officina meccanica, dove vengono realizzati la maggior parte dei componenti.

Il nostro obiettivo principale è la continua ricerca di soluzioni idonee a migliorare l'esecuzione del processo di saldatura studiando e realizzando miglioramenti continui per il cliente.



Zona Industriale 6/A - 54011 Albiano Magra (MS)
tel 0187 415277 - fax 0187 1862569
weldingtechnology@libero.it
www.weldingtechnologysrl.com

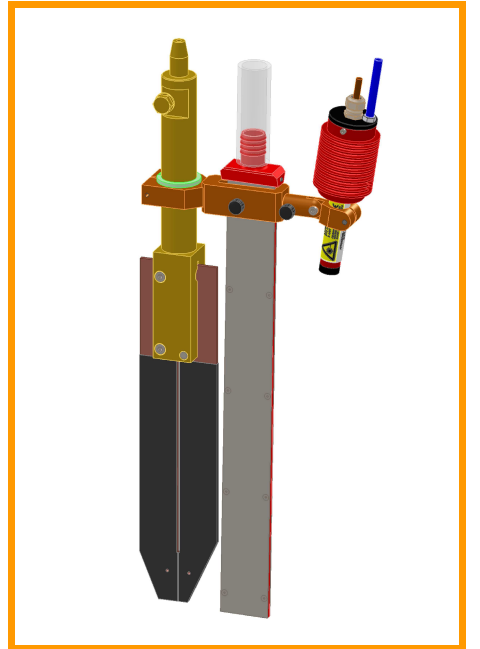
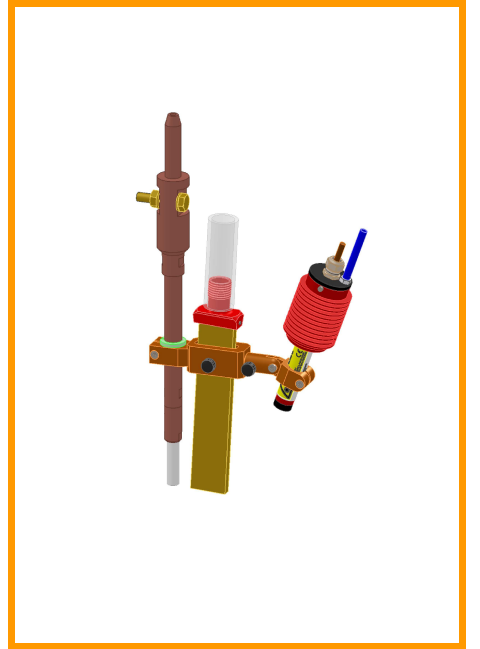

TANDEM

NARROW GAP

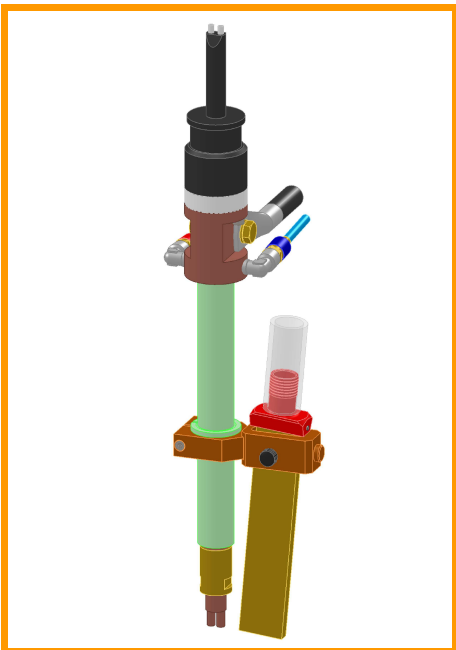

TWIN ARC

SAW per interni 10"

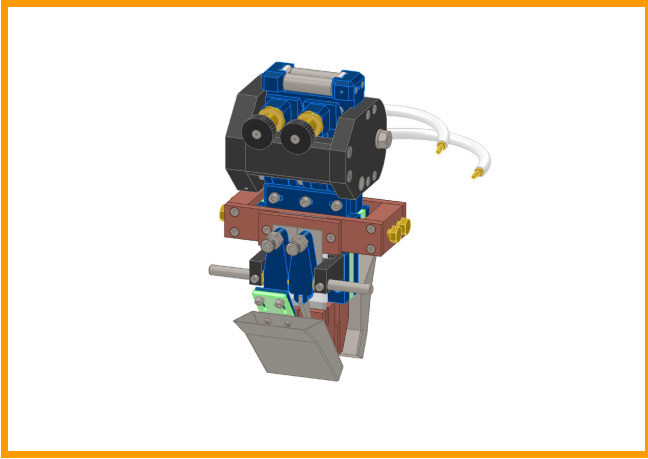

TORCIA NASTRO 60-30

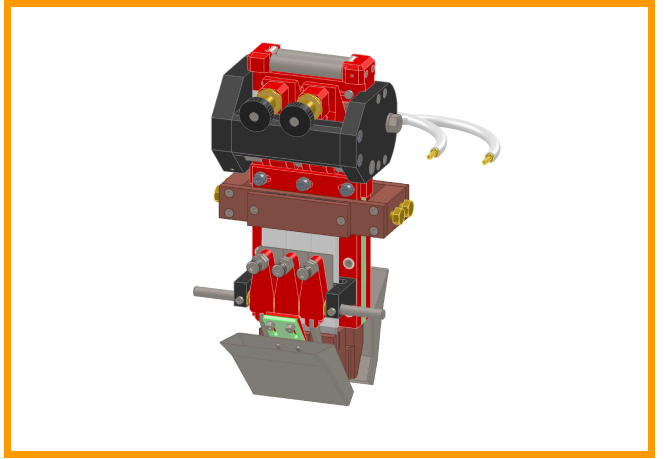

TORCIA NASTRO 90-60-30

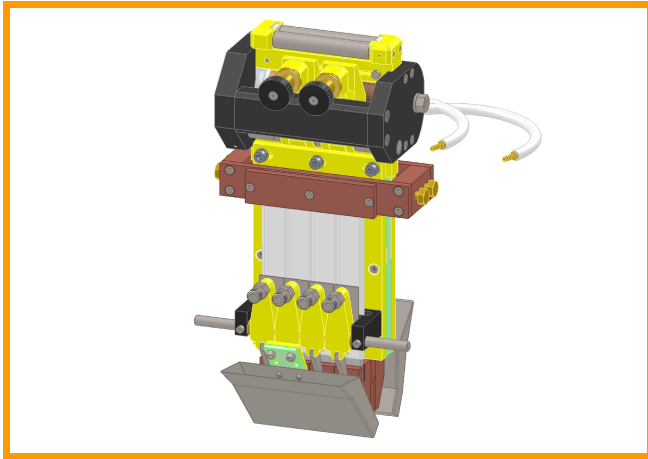

TORCIA NASTRO 120-90-60



BILANCIATORE MAGNETICO 6A - 10A

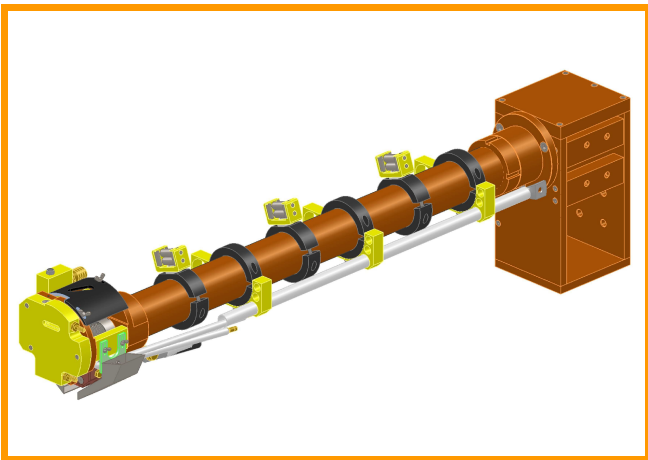

TORCIA NASTRO 30
PER INTERNI CIRCONFERENZIALE

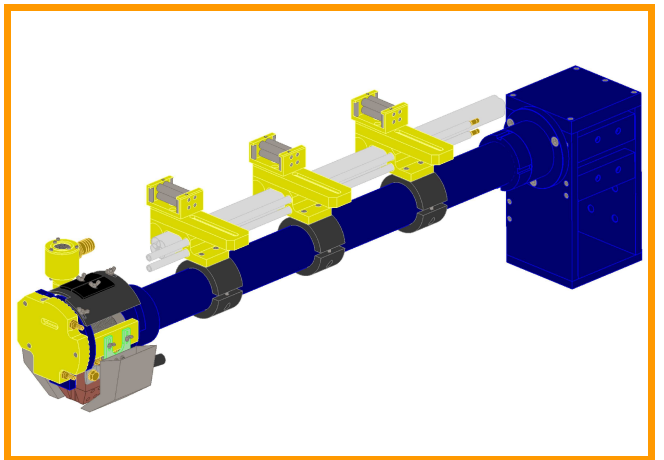

TORCIA NASTRO 60
PER INTERNI CIRCONFERENZIALE

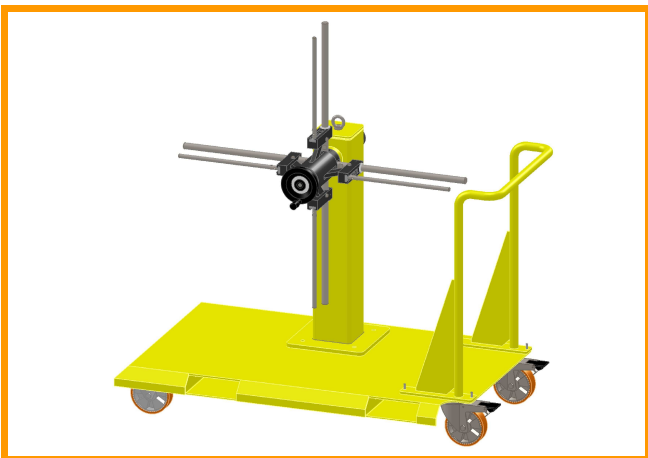

SVOLGITORE VERTICALE DEL NASTRO

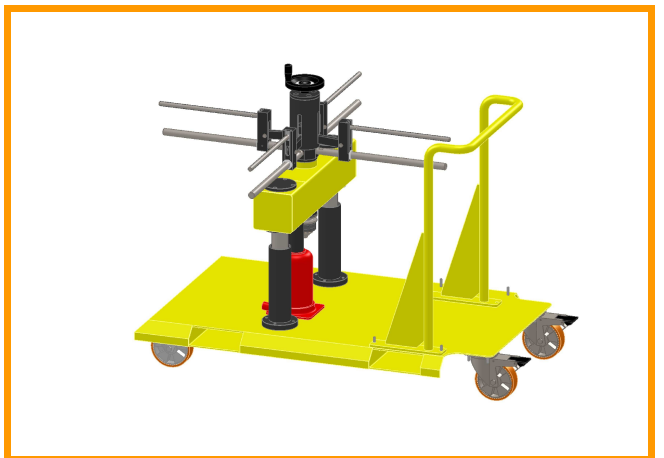

SVOLGITORE VERTICALE DEL NASTRO

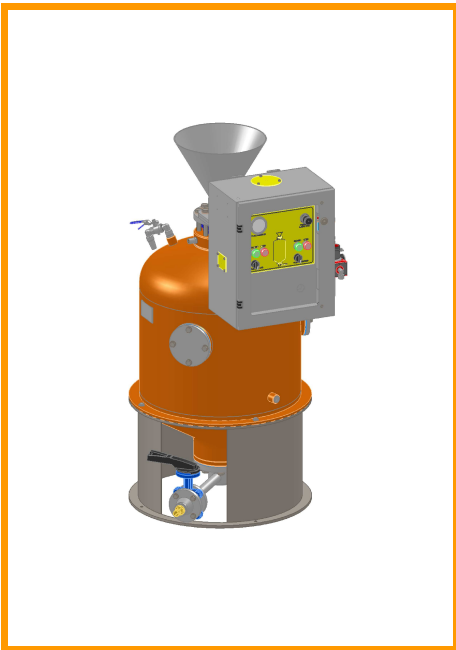

SPINTORE BASE
120 o 205 litri

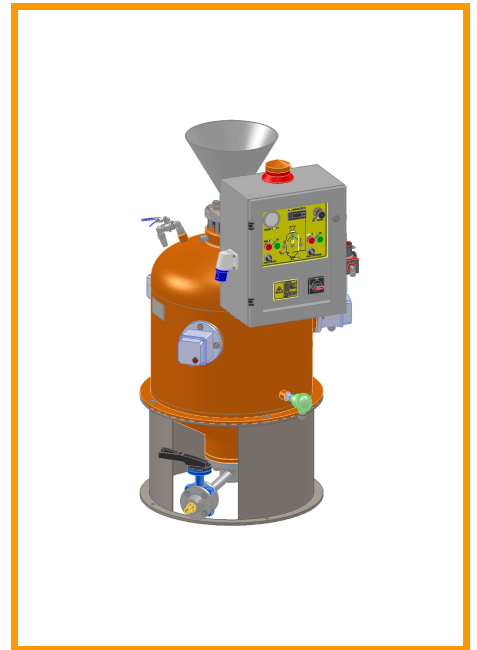

SPINTORE KIT
120 o 205 litri



SPINTORE SEMIAUTOMATICO
120 o 205 litri



SPINTORE AUTOMATICO
120 o 205 litri

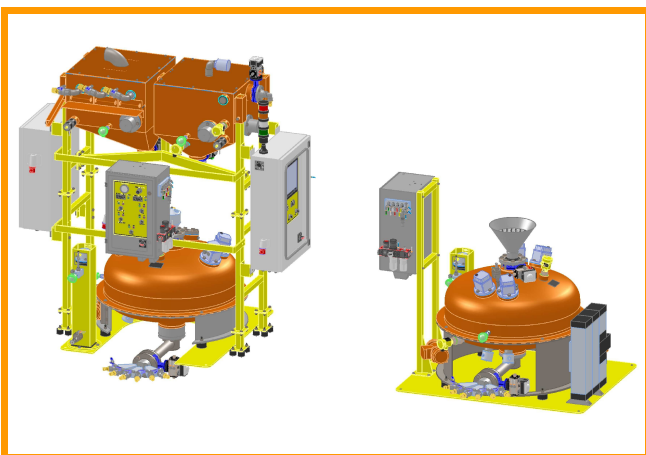

RECUPERO FLUSSO SAIPEM CASTORO 6

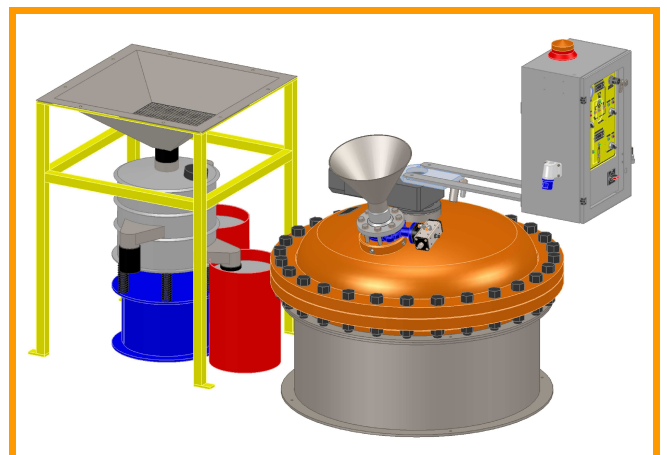

RECUPERO E MISCELAZIONE FLUSSO

RIPORTI INTERNI

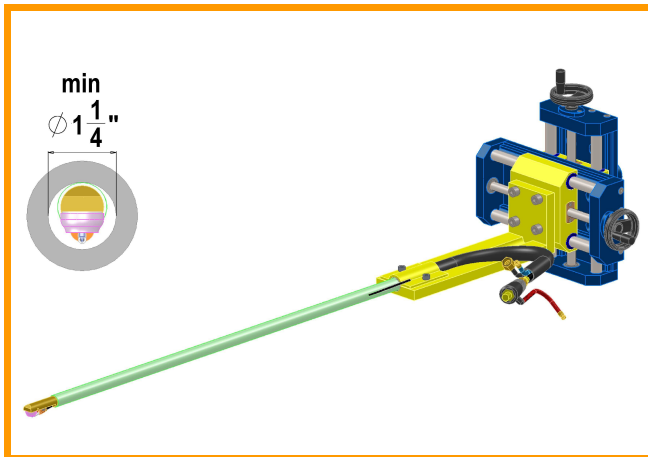

TIG 32 LONGITUDINALE

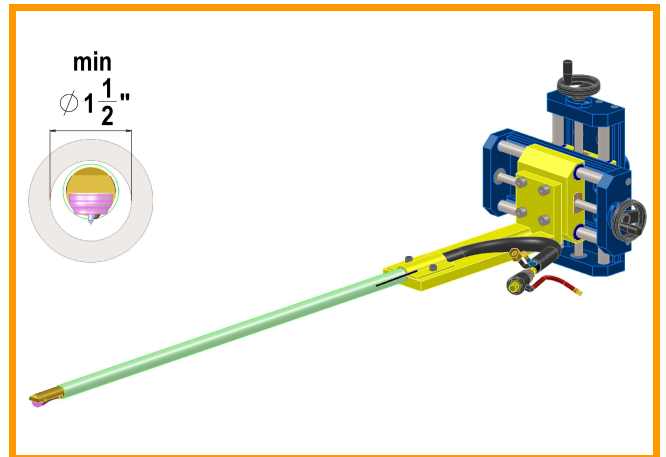

TIG 38 CIRCONFERENZIALE o LONGITUDINALE

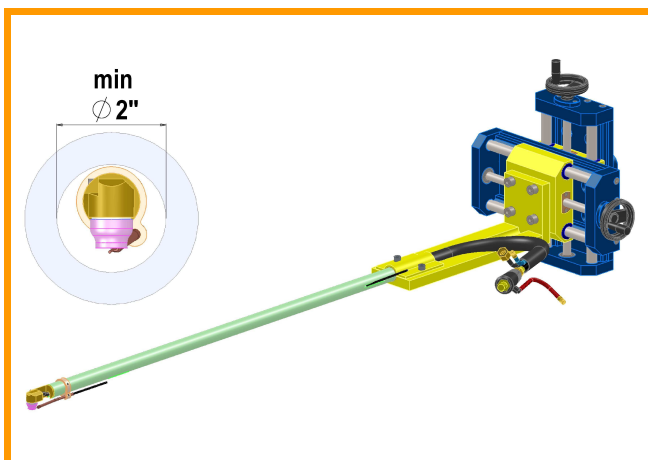

TIG 51 CIRCONFERENZIALE

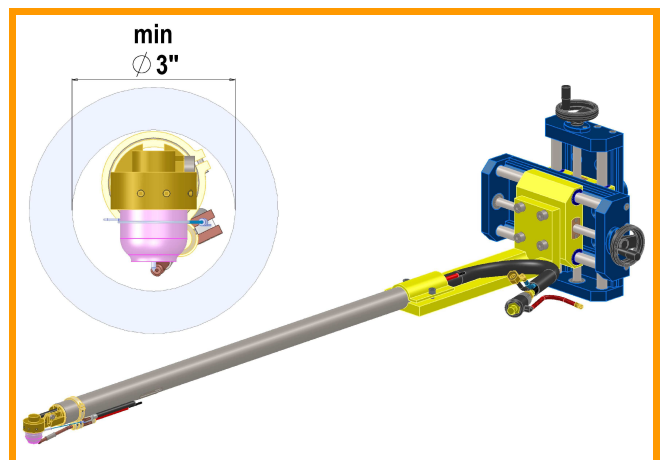

TIG 76 CIRCONFERENZIALE
FILO CALDO o FREDDO

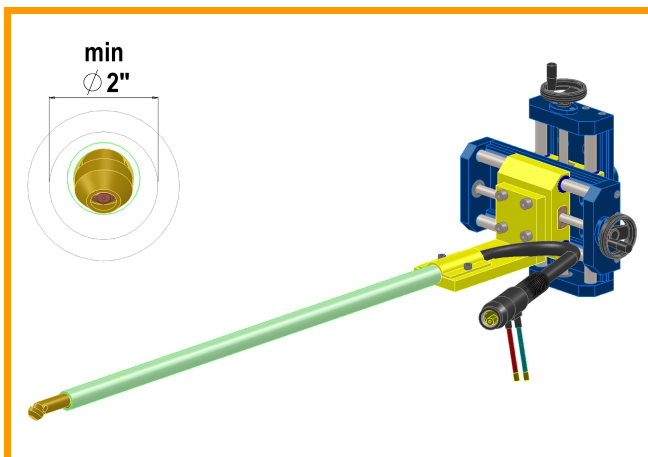

MIG 26

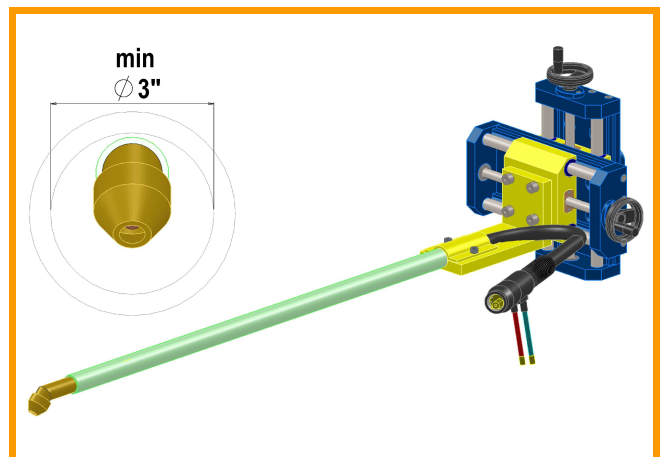

MIG 36

